

VATUSA PHOENIX TRACON and VATUSA PHOENIX ATCT

LETTER OF AGREEMENT

EFFECTIVE: 01/08/08

SUBJECT: Interfacility Coordination Procedures

1. **PURPOSE.** This Letter of Agreement establishes procedures for coordinating air traffic between Phoenix Tower (PHX) and Phoenix TRACON (P50). This agreement is supplementary to FAA Order 7110.65.
2. **DISCLAIMER.** Information contained herein is designed and specifically for use in the virtual controlling environment. It is not applicable, nor should be referenced for live operations in the National Airspace System (NAS).
3. **CANCELLAION.** Reserved
4. **DEFINITIONS.** For the purpose of applying arrival and departure routings, aircraft are grouped according to performance characteristics as follows:
 - a. Group A – Turbojets (Except C500-551 series, C25A, and EA50 aircraft)
 - b. Group B – Turboprops and C500-551 series, C25A, and EA50 aircraft
 - c. Group C – All other aircraft and helicopters
5. **RESPONSIBILITIES**
 - a. P50 delegates to PHX that airspace depicted in Annex 1 for the purpose of providing limited radar approach control functions for radar separation and Class B services.
 - b. PHX shall coordinate with P50 positions (through the Controller In Charge when available) prior to effecting runway change. PHX shall not release departures from the new active runways until authorized by P50.
 - c. Local Control shall use Tower Radar Mode at all times to maintain aircraft identification.
 - d. The PHX ATIS shall advertise visual approaches unless otherwise specified by P50.
 - e. PHX shall forward the current ATIS code and any subsequent changes to P50.
 - f. PHX and P50 shall use scratch pad entries as specified in Annex 4.
 - g. P50 authorizes PHX to assign beacon codes to helicopter traffic within 10 NM of Phoenix Sky Harbor Airport at or below 2,000' MSL.

For VATSIM Use Only

6. DEPARTURE PROCEDURES

- a. Unless otherwise specified, PHX has automatic releases for all departures.
- b. PHX is authorized to climb departing aircraft into the Sterilized Departure Airspace depicted in Annex 2.
- c. Transfer of communications shall normally be accomplished within one mile of the departure end of the runway.
- d. Local Control shall notify the appropriate departure controller via chat message when any IFR departure or VFR departure receiving radar service begins their takeoff roll. The message shall include aircraft callsign and SID with transition or direction of flight (if no SID). No reply is required from the departure controller. Notification may be suspended after coordination between PHX and the affected departure controller(s).

Example: *(Callsign), (SID or Direction)*

AWE35, BXK2.BXK

N8AT, Northeast

- e. PHX Shall:

(1) Except for Group A aircraft assigned a SID, assign the following departure headings:

Aircraft Group	Direction of Flight	West Flow	East Flow
Group A	North	Runway Hdg	Runway Hdg
	South		
Group B / IFR Group C	North	290°	040°
	South	230°	110°
VFR Group C (See Note)	North	330°	010°
	South	190°	140°

Note – Ensure VFR Group C aircraft requesting flight following enter Biltmore or Pima airspace on the assigned heading. Terminate radar service for all other VFR Group C aircraft upon leaving tower airspace and the Class B surface area.

(2) Assign the following initial altitudes:

Aircraft Group	Initial Altitude
IFR Group A	7,000' MSL
IFR Group B / C	4,000' MSL
All VFR	At or Below 4,000' MSL

- (3) Issue clearances and routes to aircraft based on the filed flight plan, issuing amendments as necessary. Aircraft able to accept a SID shall be cleared via an appropriate departure procedure and transition. Aircraft unable to accept a SID shall be cleared via radar vectors.
- (4) Ensure aircraft enter P50 airspace via the Sterilized Departure Airspace depicted in Annex 2.
- (5) Advise the appropriate P50 position of any aircraft that is not tracked (i.e. – does not display a position symbol) within 4 NM of the departure end of the runway.
- (6) Call for release of IFR departures landing SDL or DVT.
- (7) Provide initial departure separation in accordance with FAA Order 7110.65, with the following restrictions for IFR departures on the same SID / route / initial heading:
 - (a) Visual separation is not authorized.
 - (b) Provide 7 NM between Group A aircraft departing behind Group B.
 - (c) Provide 7 NM between Group B aircraft departing behind Group C.

7. ARRIVAL PROCEDURES

- a.** Verbal coordination is not required on arriving aircraft provided a radar handoff is accomplished prior to the aircraft entering PHX airspace.
- b.** PHX and P50 shall coordinate to determine active arrival runway status and any necessary arrival restrictions.
 - (1) East Flow designates Runway 7R and Runway 8 as active arrival runways.
 - (2) West Flow designates Runway 25L and Runway 26 as active arrival runways.
 - (3) Runway 7L/25R shall not be an arrival runway unless specifically coordinated.
- c.** P50 Shall:
 - (1) Be responsible for separation until 3 NM from the runway threshold.
 - (2) Enter the assigned runway and indicate whether visual separation is being applied between successive arrivals in the Scratchpad (e.g. – L is Visual Apch Runway 25L, V8 is Visual Apch Runway 8, maintaining visual separation with aircraft ahead).
 - (3) Ensure all Group A, B, and IFR Group C aircraft are established on final approach no less than 5 NM from the arrival runway threshold. VFR Group C aircraft may be sequenced to base leg.
 - (4) Instruct VFR Group C aircraft not sequenced to a straight-in final to maintain 3,000' MSL until advised by tower.
 - (5) Transfer communications between 5 and 12 NM from the arrival runway.
 - (6) Provide any coordinated miles in trail restrictions to the runway threshold.

8. GO-AROUND/MISSED APPROACH/ILS BREAK OUT PROCEDURES

- a.** PHX shall coordinate with P50 on an individual basis.
- b.** PHX may retain VFR Group C aircraft within tower airspace for re-sequencing.
- c.** While Simultaneous Dependant ILS Approaches are in use, P50 delegates PHX the Tower Breakout Corridor Airspace as depicted in Annex 3.
- d.** PHX Shall:
 - (1)** Issue any headings or altitudes necessary to maintain separation between Go-Around/ Missed Approach/ILS Break Out Aircraft and any departures, provided all aircraft remain within PHX and Sterilized Departure Airspace depicted in Annexes 1 & 2.
 - (2)** Coordinate headings and altitudes issued with the appropriate departure controller.
 - (3)** Handoff the aircraft to the appropriate departure controller.

ANNEXES

- ANNEX 1 – Phoenix Tower (PHX) Airspace
- ANNEX 2 – Sterilized Departure Airspace
- ANNEX 3 – Tower Breakout Corridor Airspace
- ANNEX 4 – Phoenix TRACON (P50) Sectors
- ANNEX 5 – Scratchpad Information

ANNEX 1 – PHX TOWER AIRSPACE

East Flow

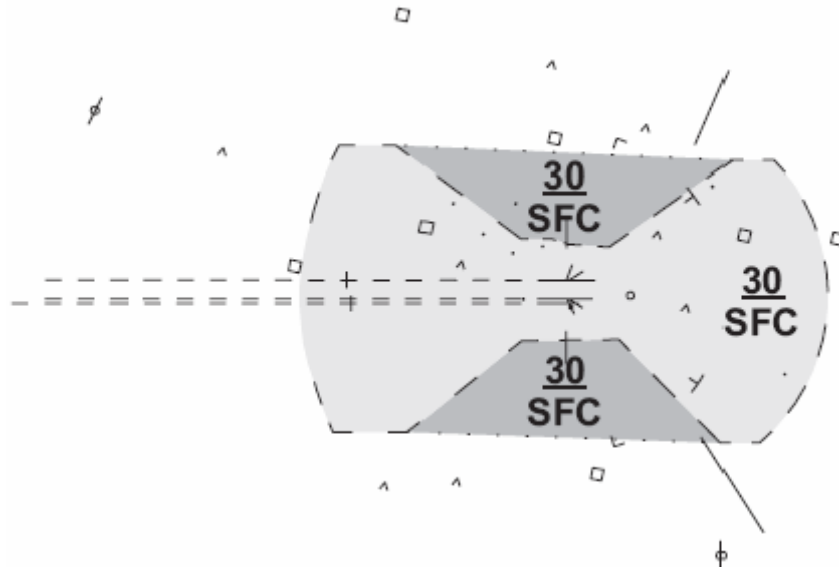

West Flow

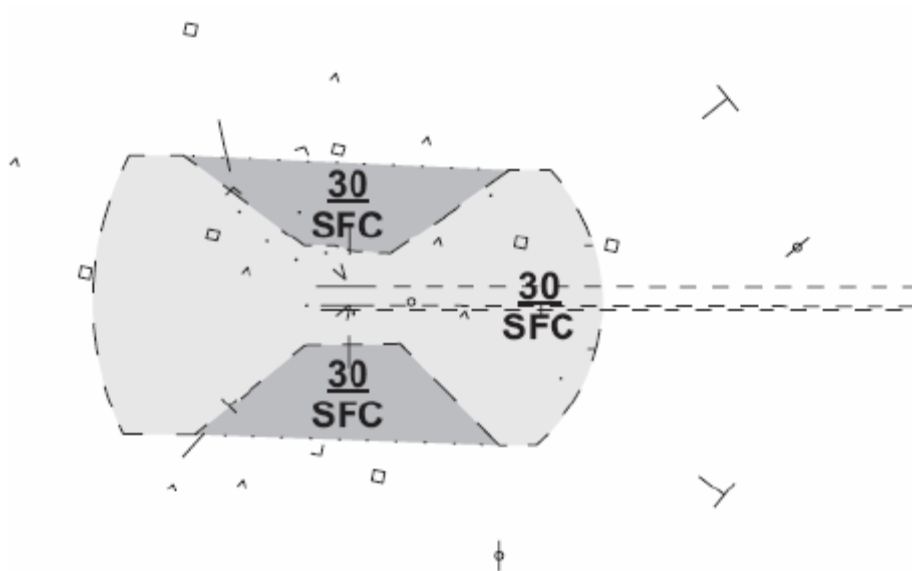

For VATSIM Use Only

ANNEX 2 – STERILIZED DEPARTURE AIRSPACE

East Flow

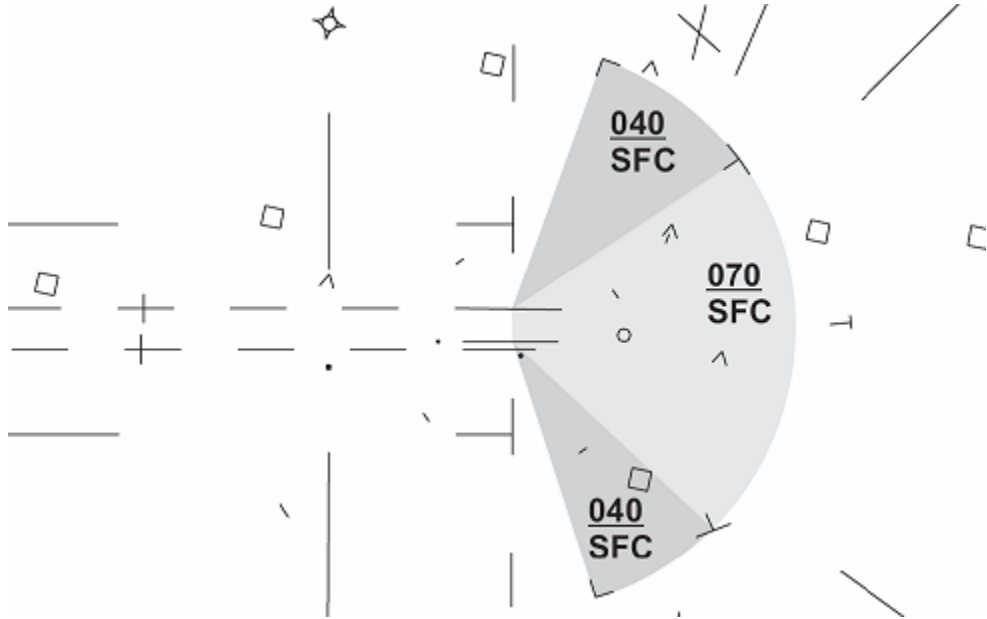

West Flow

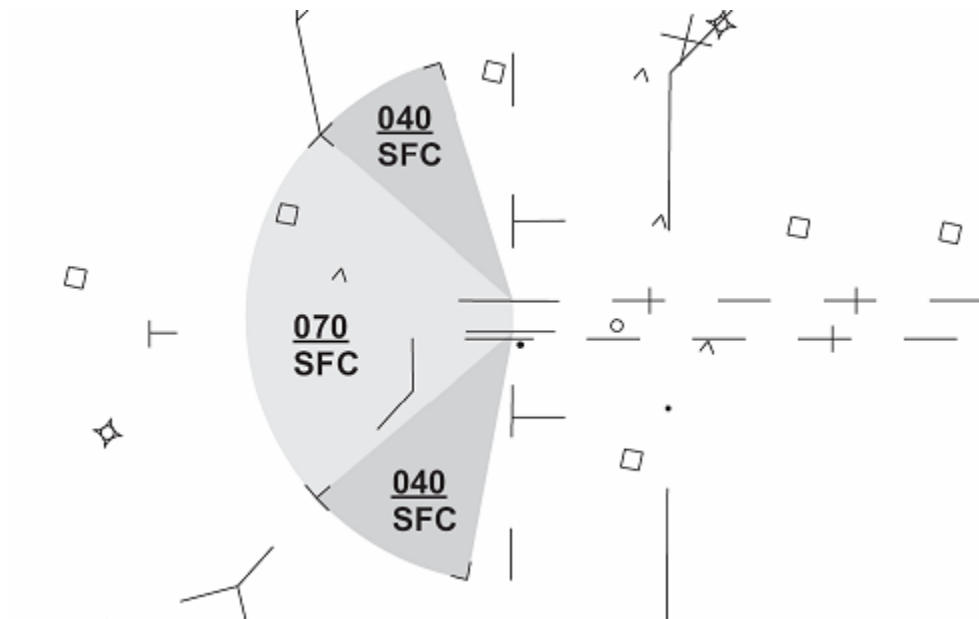

For VATSIM Use Only

ANNEX 3 – TOWER BREAKOUT AIRSPACE

East Flow

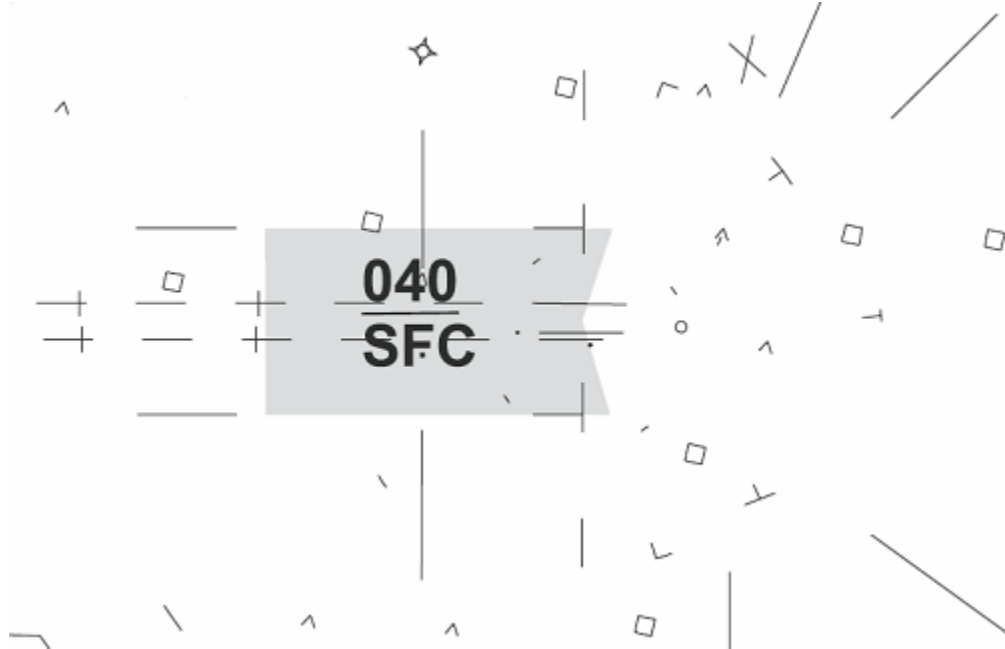

West Break

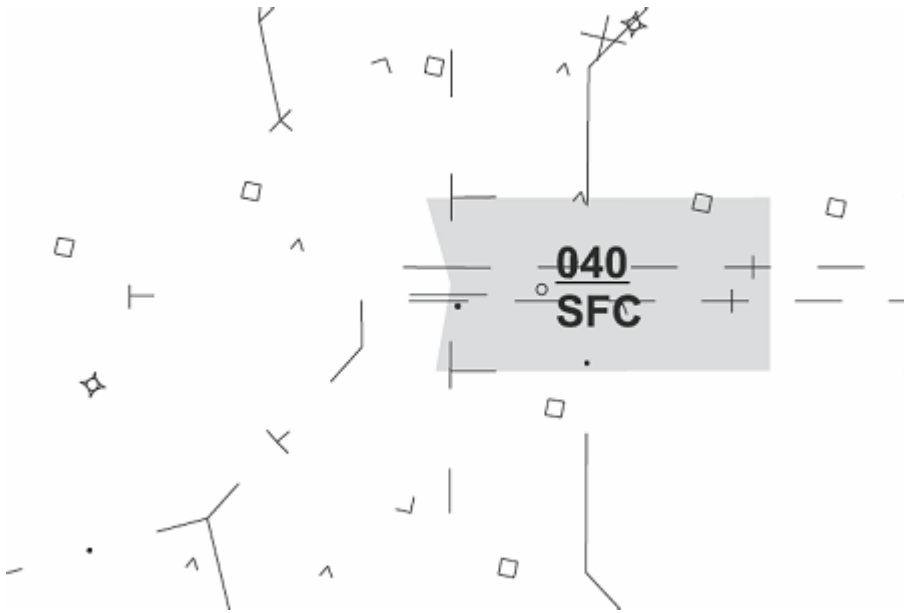

ANNEX 4 – PHOENIX TRACON (P50) SECTORS

East Flow



West Flow

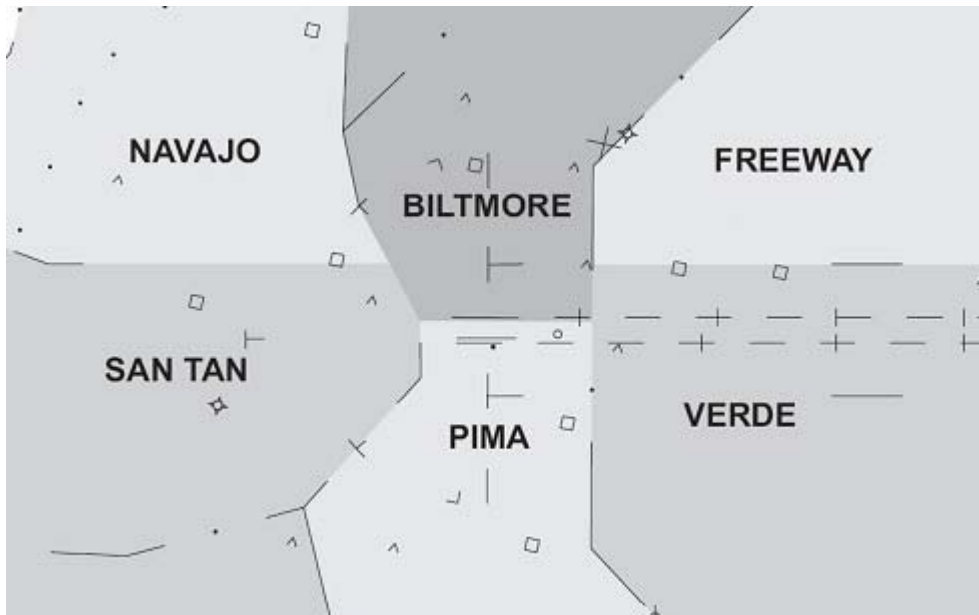

ANNEX 5 – SCRATCHPAD INFORMATION

1. Runway / Approach Assignment

- a. Enter the following characters in the Scratchpad to indicate an aircraft issued a visual approach to the assigned arrival runway:

Scratchpad Entry	West Flow Runway	East Flow Runway
L	25L	7L*
R	25R*	7R
8	N/A	8
26	26	N/A

* Assign only after coordination between PHX and P50

- b. Prefix the assigned runway characters with the following to indicate additional approach information as necessary:

Prefix (Example)	Meaning
V (V8)	Aircraft has been instructed to maintain visual separation or to follow the preceding traffic to the assigned runway
I (IL)	Aircraft is executing an ILS approach to the assigned runway
R (R26)	Aircraft is executing an RNAV approach to the assigned runway

2. **SDL VOR or GPS-A.** For aircraft landing SDL and executing the VOR or GPS-A approach, P50 shall ensure the aircraft inserts the characters “VRA” in the Scratchpad and shall point out the aircraft to PHX as necessary.